



CT-100C SERIES

SIX-SLOT VXIBUS CHASSIS

USER'S MANUAL

**P/N: 82-0102-000
Released November 16, 2007**

VXI Technology, Inc.

**2031 Main Street
Irvine, CA 92614-6509
(949) 955-1894**





TABLE OF CONTENTS

INTRODUCTION

Table of Contents	3
Certification	4
Warranty	4
Limitation of Warranty	4
Restricted Rights Legend	4
Declaration of Conformity	5
General Safety Instructions	6
Terms and Symbols	6
Warnings	6
Support Resources	8
SECTION 1	11
Introduction	11
Introduction	11
General Description	12
Backplane	12
Performance	12
Flexibility	13
CT-100C Mainframe Features	14
Voltage Monitor LEDs	15
CT-100C Specifications	17
SECTION 2	21
Installation	21
Introduction	21
Backplane	21
Remote Power-On Option	22
+5 V Standby Usage	23
Fan Speed Switch	24
Rackmount Option Installation	25
Overview	25
Rackmount Kit Installation	26
Rack Slide Installation (20" and 24")	28
Rackmount Door Kit Installation	30
Acrylic Rackmount Door Kit Installation	32
Installation of VXI Modules	34
Overview	34
Disconnecting the Mainframe	35
SECTION 3	37
Service Information	37
Introduction	37
Replicable Parts List	37
CT-100C Power Supply Replacement	38
Cleaning the Mainframe	40
INDEX	41

CERTIFICATION

VXI Technology, Inc. (VTI) certifies that this product met its published specifications at the time of shipment from the factory. VTI further certifies that its calibration measurements are traceable to the United States National Institute of Standards and Technology (formerly National Bureau of Standards), to the extent allowed by that organization's calibration facility, and to the calibration facilities of other International Standards Organization members.

WARRANTY

The product referred to herein is warranted against defects in material and workmanship for a period of three years from the receipt date of the product at customer's facility. The same warranty applies to the power supply for a period of one year. The sole and exclusive remedy for breach of any warranty concerning these goods shall be repair or replacement of defective parts, or a refund of the purchase price, to be determined at the option of VTI.

For warranty service or repair, this product must be returned to a VXI Technology authorized service center. The product shall be shipped prepaid to VTI and VTI shall prepay all returns of the product to the buyer. However, the buyer shall pay all shipping charges, duties, and taxes for products returned to VTI from another country.

VTI warrants that its software and firmware designated by VTI for use with a product will execute its programming when properly installed on that product. VTI does not however warrant that the operation of the product, or software, or firmware will be uninterrupted or error free.

LIMITATION OF WARRANTY

The warranty shall not apply to defects resulting from improper or inadequate maintenance by the buyer, buyer-supplied products or interfacing, unauthorized modification or misuse, operation outside the environmental specifications for the product, or improper site preparation or maintenance.

VXI Technology, Inc. shall not be liable for injury to property other than the goods themselves. Other than the limited warranty stated above, VXI Technology, Inc. makes no other warranties, express or implied, with respect to the quality of product beyond the description of the goods on the face of the contract. VTI specifically disclaims the implied warranties of merchantability and fitness for a particular purpose.

RESTRICTED RIGHTS LEGEND

Use, duplication, or disclosure by the Government is subject to restrictions as set forth in subdivision (b)(3)(ii) of the Rights in Technical Data and Computer Software clause in DFARS 252.227-7013.

VXI Technology, Inc.
2031 Main Street
Irvine, CA 92614-6509 U.S.A.

DECLARATION OF CONFORMITY

Declaration of Conformity According to ISO/IEC Guide 22 and EN 45014

MANUFACTURER'S NAME	VXI Technology, Inc.
MANUFACTURER'S ADDRESS	2031 Main Street Irvine, California 92614-6509
PRODUCT NAME	Six-Slot VXIbus Chassis
MODEL NUMBER(S)	CT-100C
PRODUCT OPTIONS	All
PRODUCT CONFIGURATIONS	All

VXI Technology, Inc. declares that the aforementioned product conforms to the requirements of the Low Voltage Directive 73/23/EEC and the EMC Directive 89/366/EEC (inclusive 93/68/EEC) and carries the "CE" mark accordingly. The product has been designed and manufactured according to the following specifications:

SAFETY	EN61010 (2001)
EMC	EN61326 (1997 w/A1:98) Class A CISPR 22 (1997) Class A VCCI (April 2000) Class A ICES-003 Class A (ANSI C63.4 1992) AS/NZS 3548 (w/A1 & A2:97) Class A FCC Part 15 Subpart B Class A EN 61010-1:2001

I hereby declare that the aforementioned product has been designed to be in compliance with the relevant sections of the specifications listed above as well as complying with all essential requirements of the Low Voltage Directive.

November 2007



Steve Mauga, QA Manager

GENERAL SAFETY INSTRUCTIONS

Review the following safety precautions to avoid bodily injury and/or damage to the product. These precautions must be observed during all phases of operation or service of this product. Failure to comply with these precautions, or with specific warnings elsewhere in this manual, violates safety standards of design, manufacture, and intended use of the product.

Service should only be performed by qualified personnel.

TERMS AND SYMBOLS

These terms may appear in this manual:

- WARNING** Indicates that a procedure or condition may cause bodily injury or death.
- CAUTION** Indicates that a procedure or condition could possibly cause damage to equipment or loss of data.

These symbols may appear on the product:



ATTENTION - Important safety instructions



Frame or chassis ground



Indicates that the product was manufactured after August 13, 2005. This mark is placed in accordance with *EN 50419, Marking of electrical and electronic equipment in accordance with Article 11(2) of Directive 2002/96/EC (WEEE)*. End-of-life product can be returned to VTI by obtaining an RMA number. Fees for take-back and recycling will apply if not prohibited by national law.

WARNINGS

Follow these precautions to avoid injury or damage to the product:

- Use Proper Power Cord** To avoid hazard, only use the power cord specified for this product.
- Use Proper Power Source** To avoid electrical overload, electric shock, or fire hazard, do not use a power source that applies other than the specified voltage.

WARNINGS (CONT.)

Avoid Electric Shock

To avoid electric shock or fire hazard, do not operate this product with the covers removed. Do not connect or disconnect any cable, probes, test leads, etc. while they are connected to a voltage source. Remove all power and unplug unit before performing any service. *Service should only be performed by qualified personnel.*

Ground the Product

This product is grounded through the grounding conductor of the power cord. To avoid electric shock, the grounding conductor must be connected to earth ground.

Operating Conditions

To avoid injury, electric shock or fire hazard:

- Do not operate in wet or damp conditions.
- Do not operate in an explosive atmosphere.
- Operate or store only in specified temperature range.
- Provide proper clearance for product ventilation to prevent overheating.
- DO NOT operate if any damage to this product is suspected. *Product should be inspected or serviced only by qualified personnel.*



Improper Use

The operator of this instrument is advised that if equipment is used in a manner not specified in this manual, the protection provided by this equipment may be impaired.

SUPPORT RESOURCES

Support resources for this product are available on the Internet and at VXI Technology customer support centers.

VXI Technology World Headquarters

VXI Technology, Inc.
2031 Main Street
Irvine, CA 92614-6509

Phone: (949) 955-1894
Fax: (949) 955-3041

VXI Technology Cleveland Instrument Division

VXI Technology, Inc.
7525 Granger Road, Unit 7
Valley View, OH 44125

Phone: (216) 447-8950
Fax: (216) 447-8951

VXI Technology Lake Stevens Instrument Division

VXI Technology, Inc.
1924 - 203 Bickford
Snohomish, WA 98290

Phone: (425) 212-2285
Fax: (425) 212-2289

Technical Support

Phone: (949) 955-1894
Fax: (949) 955-3041
E-mail: support@vxitech.com



Visit <http://www.vxitech.com> for worldwide support sites and service plan information.

SECTION 1

INTRODUCTION

INTRODUCTION

The CT-100C portable C-size VXIbus mainframe provides cost-effective test situations in a small footprint. When using VMIP™ instruments such as DMMs, waveform generators, digitizers, etc., complete test scenarios can easily be configured.



FIGURE 1-1: CT-100C SIX SLOT CHASSIS

GENERAL DESCRIPTION

The CT-100C chassis is a portable, C-size, six-slot, VXIbus compatible chassis that conforms fully to VXIbus Specification Revision 2.0. The chassis employs a multi-layer backplane to ensure premium VXIbus and VMEbus performance and provides all power supplies required by the VXIbus specification.

The CT-100C supports conventional existing rack designs through an optional rackmounting kit (see Section 1). The six-slot design minimizes the use of precious rack space and is an economical alternative to a larger chassis when fewer slots are required.

The CT-100C chassis contains six slots in the card cage, five of which are available for use by VXIbus compatible instruments. The sixth slot in the card cage (slot 0) is typically dedicated to the VXIbus Resource Manager.

The CT-100C is designed to operate at line frequencies between 47 Hz and 63 Hz and utilizes a power supply that automatically adjusts to accept line voltages between 100 V ac and 240 V ac. There is an internal fuse that provides protection against catastrophic failures and is designed to operate within the valid input range.

The rear panel provides a connector for 5V STANDBY. Power supplied to this connector is passed directly to the backplane line +5V STDBY. This allows properly configured systems to take advantage of an alternate power supply source, i.e., battery backup of memory or energizing high stability reference oscillators.

BACKPLANE

The backplane is a monolithic, multi-layer design, with automatic, solid-state daisy-chain jumpering for the interrupt acknowledge and VMEbus grant lines. This eliminates the need for manual jumpering and provides improved reliability over mechanical jumper-less backplane designs. Instrument modules can now be added or removed without concern for the backplane configuration.

PERFORMANCE

The CT-100C uses a pressurized airflow system. As air enters the mainframe from the rear, it is pressurized below the cards and is then evenly distributed across all slots and along the total length of each card slot, avoiding hot spots common in other designs. The air exhausts through the top and away from the user. This cooling approach helps increase MTBF (Mean Time Before Failure) figures and module performance.

High-quality power supplies are used in the CT-100C that are UL, CSA, and TUV approved. The power supplies are short-circuit, over-voltage, reverse-voltage and thermal-shutdown protected. Auto-ranging power supplies are used to avoid any concern about the voltage source used. In addition, all supply lines are monitored and displayed on the front panel to provide user feedback of correct operation (see Figure 1-4).

FLEXIBILITY

The CT-100C is designed to provide flexibility of use in bench-top and rackmount applications, as well as in portable environments. The outside cover is removable for easy access to the VXIbus modules during bench-top development, troubleshooting, or calibration. For rackmount applications, a rackmount kit allows the CT-100C to mount flush or be recessed four inches. A latched door is provided with the rackmount kit, which can be user-modified to accept connectors, switches, or indicators. See Section 1 for rackmount installation.

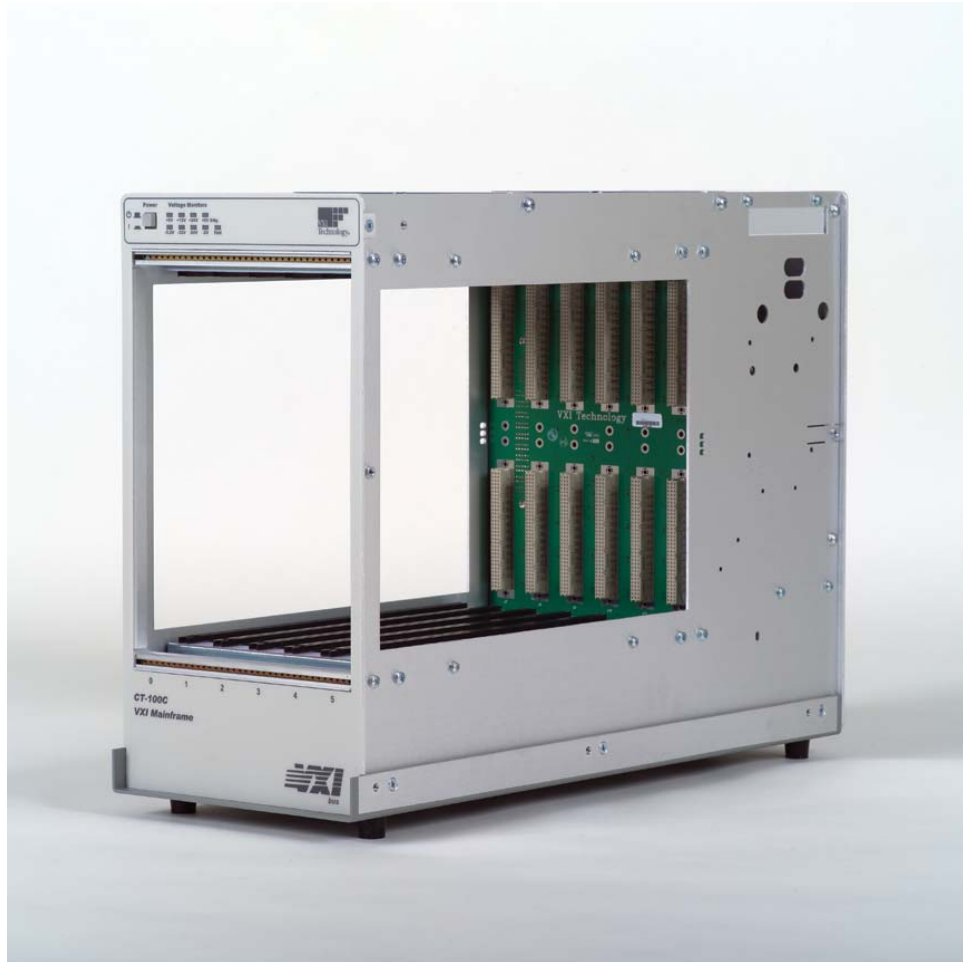

FIGURE 1-2: CT-100C SIX-SLOT CHASSIS – COVERS OFF

CT-100C MAINFRAME FEATURES

FRONT PANEL FEATURES

POWER SWITCH

Feature 1 When elevated, the mainframe is in standby mode, where power is supplied to the mainframe, but not to the VXI modules. When depressed, power is supplied to both mainframe and VXI modules

VOLTAGE INDICATORS

Feature 2 Indicates whether specific backplane voltages are within specifications. See Figure 1-4 for details.

FAN INDICATOR

Feature 3 Indicates whether the fan voltages are within specifications. See Figure 1-4 for details.

REAR PANEL FEATURES

FAN SPEED SWITCH

Feature 4 Enables the user to vary the speed of the fan between HIGH and LOW. See Figure 1-3 for details.

J200 CONNECTOR

Feature 5 AC power receptacle.

GROUND STUD

Feature 6 Used to electrical ground the mainframe.

J201 CONNECTOR

Feature 7 See Figure 1-5 and Table 1-1 for connector pin assignments.

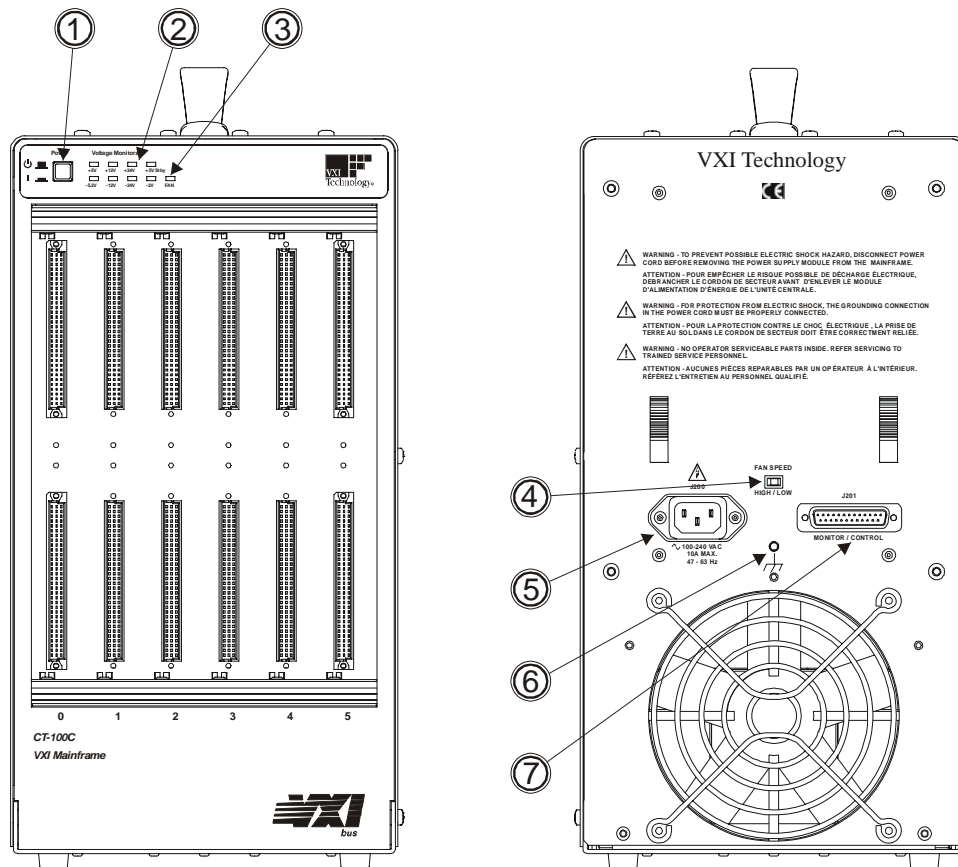
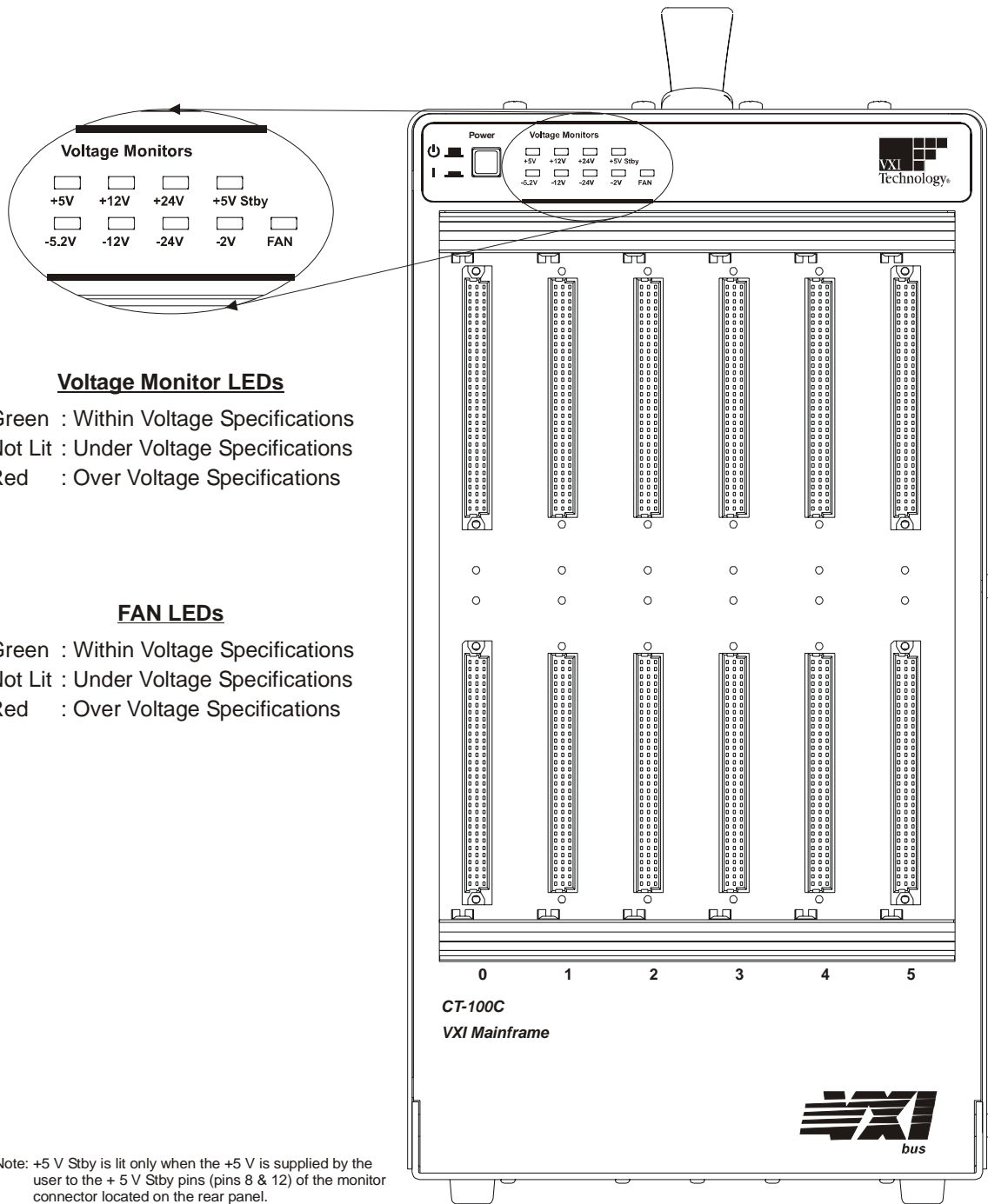

FIGURE 1-3: MAINFRAME FEATURE LOCATIONS

VOLTAGE MONITOR LEDs

The power supply lines are monitored and displayed on the front panel, providing information pertaining to the chassis operational status.



*Note: +5 V Stby is lit only when the +5 V is supplied by the user to the + 5 V Stby pins (pins 8 & 12) of the monitor connector located on the rear panel.

NOTE At power up, the voltage monitor LED may blink for the first several seconds if the fan speed is set to "HIGH".

FIGURE 1-4: FRONT PANEL VOLTAGE MONITORS

TABLE 1-1: J201 CONNECTOR PIN ASSIGNMENTS

Pin Number	Description
1	+5 V Monitor [‡]
2	-12 V Monitor [‡]
3	-24 V Monitor [‡]
4	-2 V Monitor [‡]
5	Remote Power Switch
6	+5 V Output [‡]
7	+12 V Output [‡]
8	+5 V Standby Input
9	Ground
10	Backplane Reset I/O
11	N/C
12	N/C
13	Fan OK Output
14	+12 V Monitor [‡]
15	+24 V Monitor [‡]
16	-5.2 V Monitor [‡]
17	Ground
18	Remote Power Switch Return
19	Ground
20	Ground
21	+5 V Standby
22	Ground
23	AC Fail I/O
24	Ground
25	N/C

NOTE

Monitor lines function as outputs only.

[‡] Pin 6 and Pin 7 (+5 V Output and +12 V Output, respectively) can provide 0.5 A from the power supply.

Both jackscrews connect to ground.

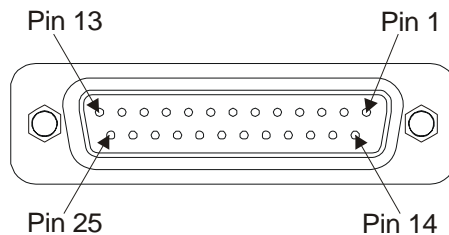
**FIGURE 1-5: J201 CONNECTOR PIN DETAIL**

CT-100C SPECIFICATIONS

GENERAL SPECIFICATIONS	
SIZE	6.96" (176.78 mm) W x 15.00" (381.00 mm) H x 21.3" D (541.02 mm) Six C-size VXIbus card slots (see Figure 1-6 for details)
WEIGHT	22 lb / 10 kg
VXIbus VERSION	2.0
MTBF	100,000 hr
MTTR	5 min
ENVIRONMENTAL SPECIFICATIONS	
OPERATING LOCATION	This chassis should be operated indoors in a controlled environment, protected from exposure to the elements (i.e. direct sunlight, precipitation, wind, etc.). Pollution degree 2. Installation Category II.
TEMPERATURE	
Operating	0 °C to +55 °C
Storage	-40 °C to +70 °C
HUMIDITY	
Operating	Up to 95% (non-condensing) at up to 30 °C; up to 45% at up to 55 °C
Non-operating	Up to 95% (non-condensing) at up to 55 °C
ALTITUDE	
Operating	15,000 ft (4,570 m)
Non-operating	40,000 ft (12,190 m)
RANDOM VIBRATION*	
Operating	0.27 g-rms total from 5 Hz to 55 Hz
Non-operating	2.28 g-rms total from 5 Hz to 55 Hz
<i>* Three axis, 30 min total, 10 min per axis.</i>	
FUNCTIONAL SHOCK	
Operating	Half sine, 30 g, 11 ms duration Meets functional shock requirements of MIL-T-28800E, Type III, Class 5

POWER SPECIFICATIONS**USEABLE POWER**

500 W to 50 °C, derated by 2.5%/°C above 50 °C

DC SUPPLY VOLTAGE

Voltage	Peak Current (I _{MP})	Dynamic Current (I _{MD})	Allowed Variation	Ripple/Noise DC Load	Induced Ripple Noise
+5 V	40 A	5 A	+0.25 V / -0.125 V	50 mV	50 mV
-5.2 V	10 A	5 A	-0.26 V / +0.125 V	50 mV	50 mV
-2 V	8 A	2 A	-0.10 V / +0.72 V	50 mV	50 mV
+12 V	8 A	2 A	+0.60 V / -0.36 V	50 mV	50 mV
-12 V	4 A	2 A	-0.60 V / +0.36 V	50 mV	50 mV
+24 V	4 A	2 A	+1.20 V / -0.72 V	150 mV	150 mV
-24 V	4 A	2 A	-1.20 V / +0.74 V	150 mV	150 mV

POWER INPUT**Input Voltage / Freq.****Nominal AC**

Minimum 100 V ac to a maximum 240 V ac, 50 Hz/60 Hz

Inrush Current

< 40 A (cold start)

Input Power

10 A max

Input Leakage

< 1.24 MA @ 264 V ac, 53 Hz

Input Harmonics

Meets EN61000-3-2

Fuse

Internal and independent of line voltage (not user accessible)

POWER SUPPLIES

UL, CSA, TUV approved, CE marked

Shunt circuit, over-voltage, reverse voltage and thermal shutdown protection

COOLING SPECIFICATIONS**COOLING REQUIREMENTS*****Low Fan Speed**

56 W/slot for a 10°C Rise

84 W/slot for a 15°C Rise

High Fan Speed

80 W/slot for a 10°C Rise

120 W/slot for a 15°C Rise

Calculated using VXI-8 Rev. 2.0 standards*COOLING MODES**

High or low speed cooling modes can be selected by moving the Fan Speed switch at the rear of the chassis. The power supply and modules are cooled by separate fans.

AIR FLOW PATH

Air is drawn into the chassis from the rear and is pressurized below the cards. The air is then distributed across all slots along the total length of each slot and is exhausted through the top of the mainframe. When the mainframe is rack mounted, allow approximately 2 inches (50 mm) of clearance at the top and rear for proper airflow.

ACOUSTIC NOISE

High Speed Fan Mode < 40 dBA

Low Speed Fan Mode < 30 dBA

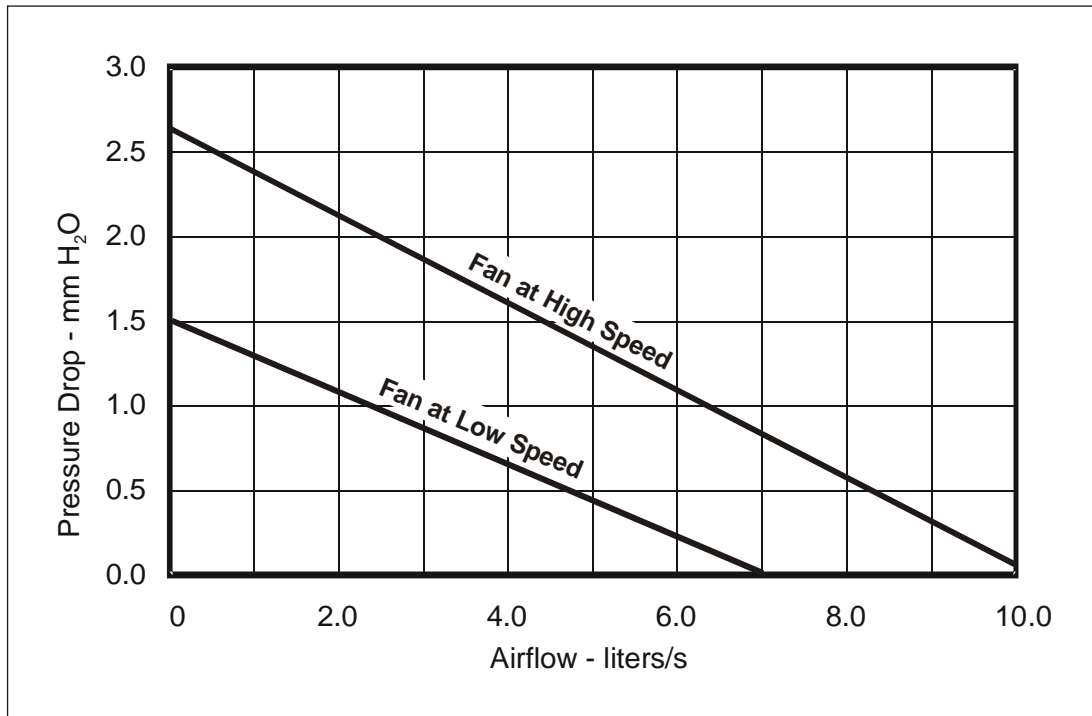

* Covers all slots, unrestricted

FIGURE 1-6: COOLING CAPACITY FOR CT-100C

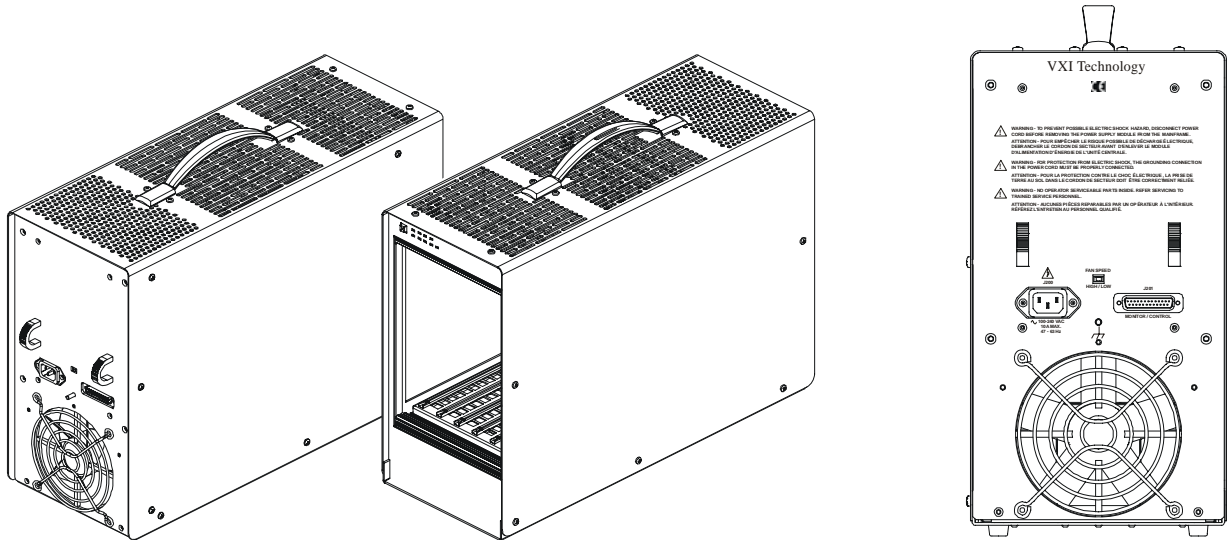
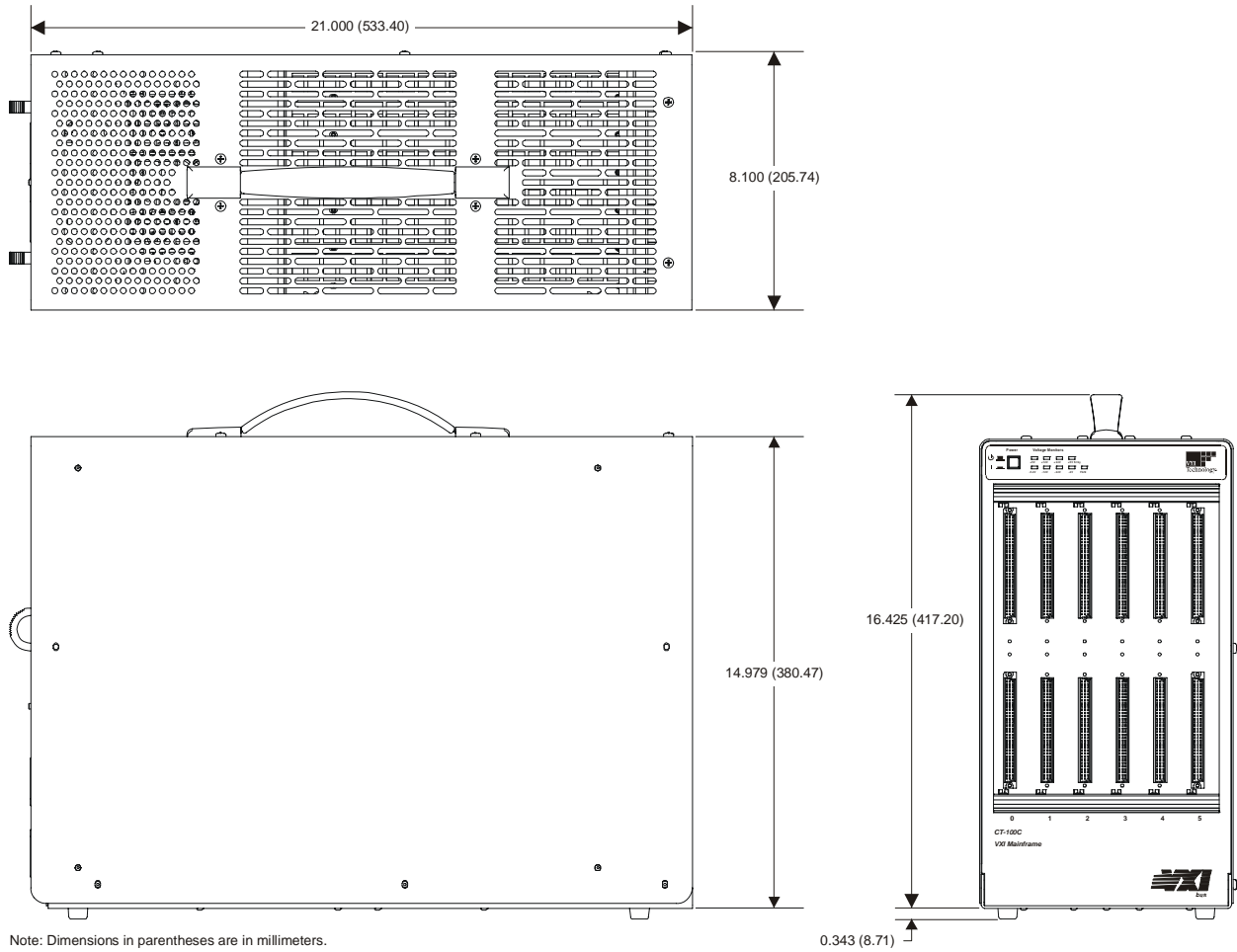

FIGURE 1-7: CT-100C DIMENSIONAL DIAGRAM

SECTION 2

INSTALLATION

INTRODUCTION

When the CT-100C is unpacked from its shipping carton, the contents should include the following items:

- (1) CT-100C Six-Slot Chassis
- (1) CT-100C Module User's Manual (this manual)
- (1) Power cord

All components should be immediately inspected for damage upon receipt of the unit.

BACKPLANE

The CT-100C mainframe has a jumper-less, auto-configurable backplane using active-automatic daisy chaining for the VME Interrupt acknowledge and bus grant daisy chain signal lines. This eliminates the need to manually configure the backplane and insures that these signals are properly configured at all times.

The power cord is the only way to disconnect the CT-100C mainframe from ac power. Therefore, the power cord must be accessible to the operator at all times. When the CT-100C mainframe is mounted in a system rack, the power cord need not be accessible since the rack must have its own disconnect device.



Le cordon de secteur est la seule manière de démonter l'unité centrale de CT-100C du courant alternatif. Par conséquent, le cordon de secteur doit être accessible à l'opérateur à tout moment. Quand l'unité centrale de CT-100C est montée dans un support de système, le cordon de secteur n'a pas besoin d'être accessible puisque le support doit avoir son propre dispositif de débranchement.

REMOTE POWER-ON OPTION

If the CT-100C mainframe is to be installed in a remote location, it is possible to apply and remove power from the unit via the remote power pins located on connector J201. To utilize the remote power feature, set the front panel switch to the standby position. Remove the power cord, then remove the power supply from the chassis and place the jumper on the power interface board to the 2 – 3 position (see Figure 2-1 for power supply removal instructions). The power interface board will be located inside the mainframe at the top right. Doing this will disable the front panel power switch. Pins 5 and 18 can now be used to remotely control the powering of the chassis. The circuit is diagramed below:

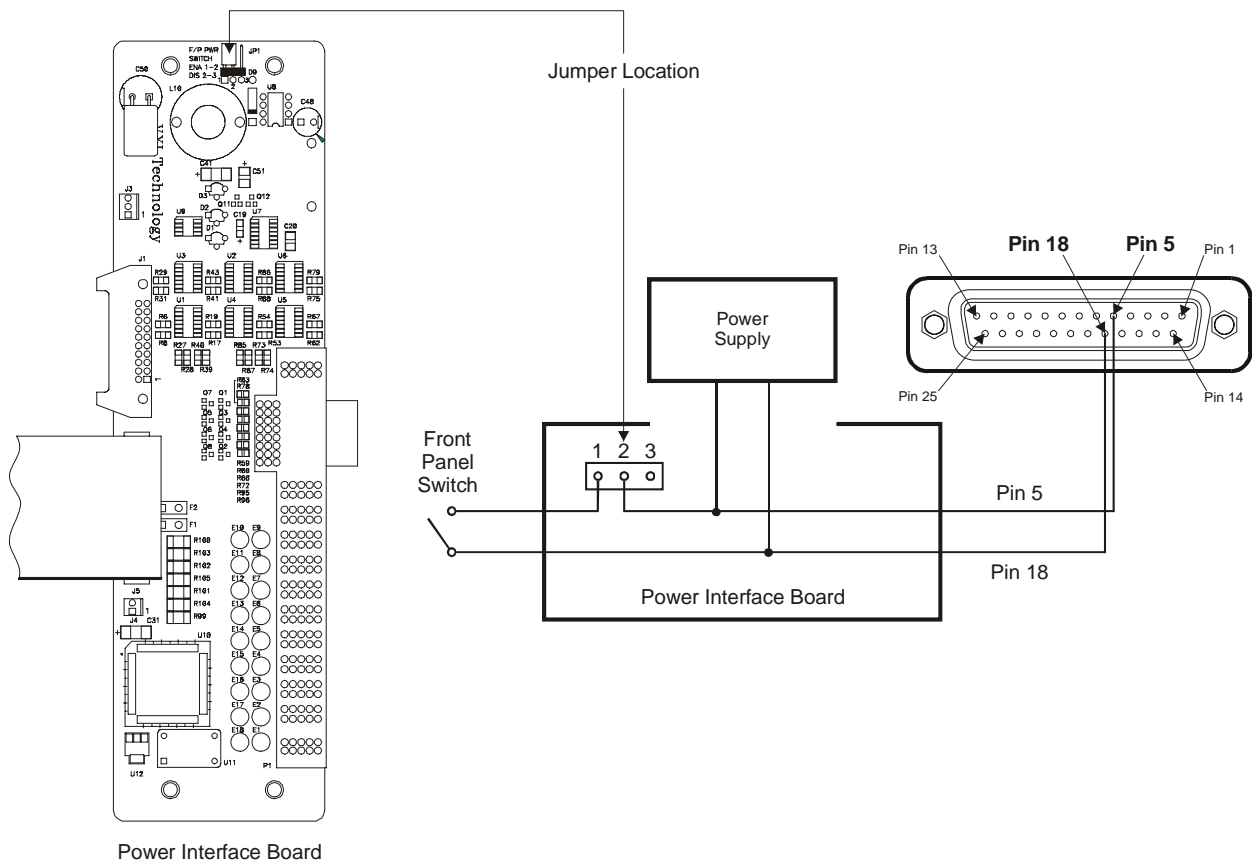

FIGURE 1-1: REMOTE POWER-ON SWITCH WIRING

+5 V STANDBY USAGE

To prevent timers and other circuits from loosing power when the CT-100C is in standby mode, +5 V Standby pins are made available on connector J201. An external power source can be wired to these pins with a maximum allowed current of 1 A total across Pins 8 and 21, as these pins are wired in parallel.

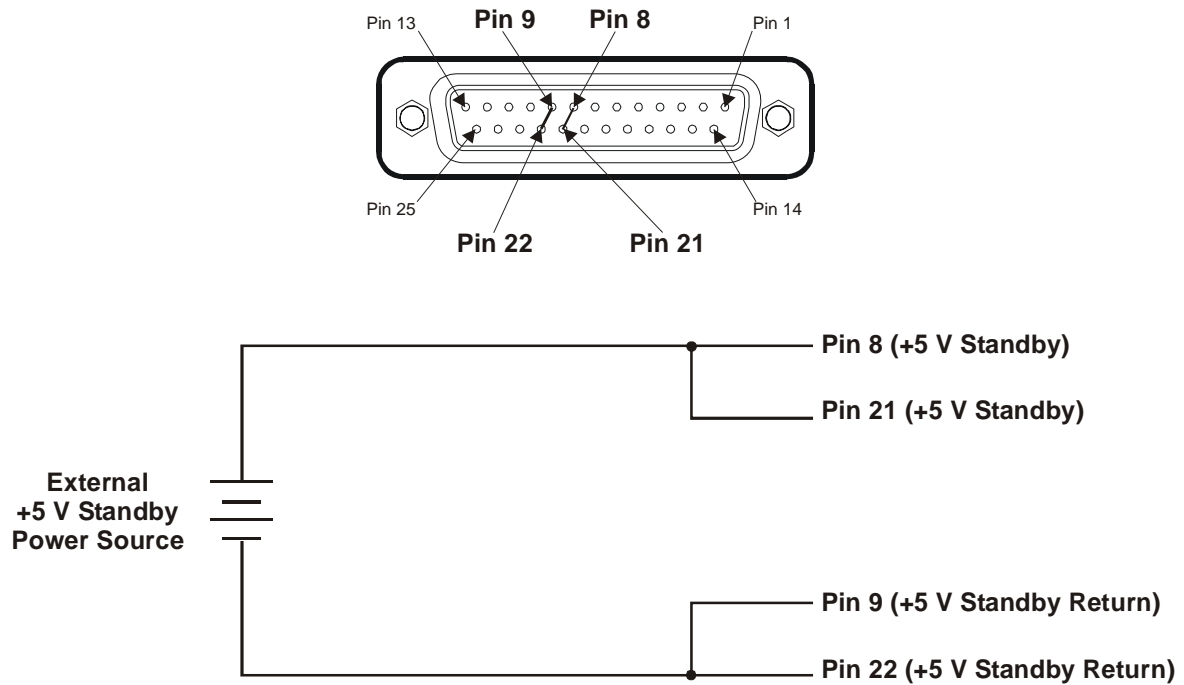

FIGURE 1-2: +5 V STANDBY WIRING DIAGRAM

FAN SPEED SWITCH

A fan speed selector switch is located at the rear of the CT-100C chassis. To set the fans to operate at HIGH speed, move the switch at the rear of the chassis to the left. At HIGH speed, the chassis is provided maximum cooling to the instruments.

The fans will operate in the LOW speed mode when the fan speed switch is toggled to the right. The low speed mode provides for quieter operation, but decreases the cooling capability of the fans. To best determine which mode of operation is best in a given application, refer to Figure 1-6 on page 19 that delineates the cooling requirements of populated mainframes. If all instruments installed in the chassis receive adequate cooling in the low speed mode, then this mode may be used.

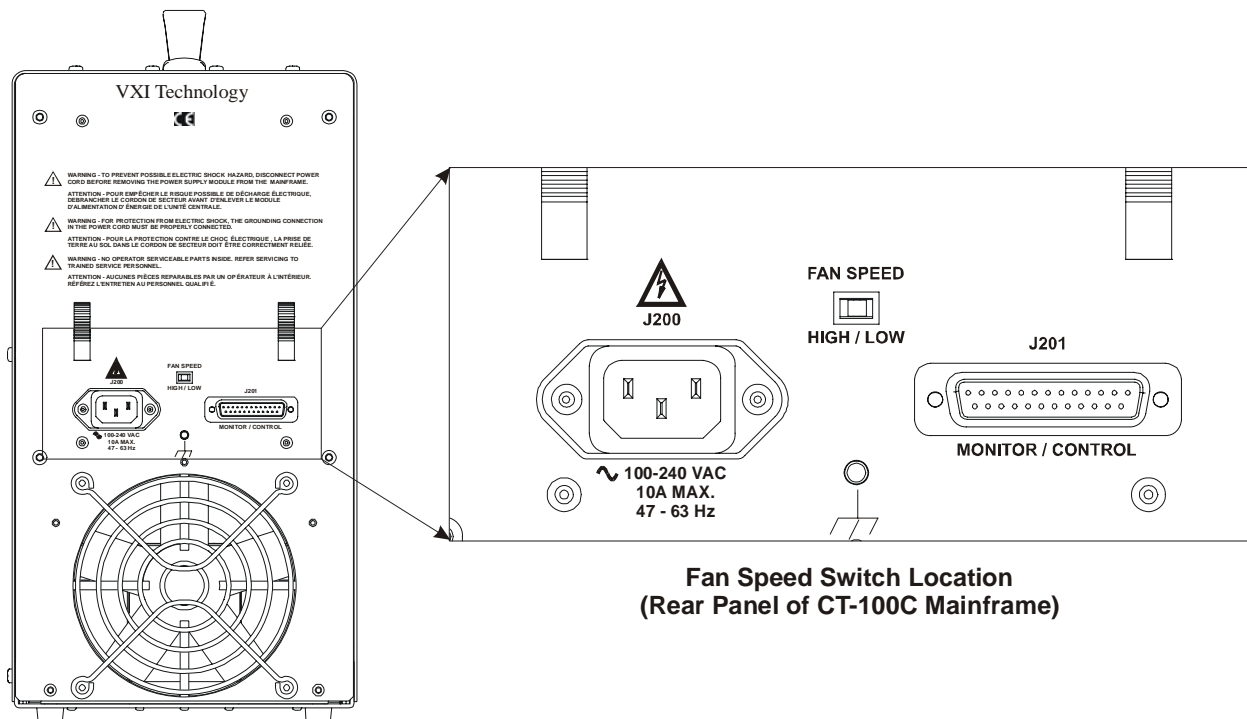

FIGURE 1-3: FAN SPEED SWITCH LOCATION

RACKMOUNT OPTION INSTALLATION

OVERVIEW

This section contains the procedures for installing a CT-100C chassis in a standard 19" relay rack. The available rackmounting options are:

- Option 52 – Rackmount Ear Kit
- Option 53 – Rackmount Door Kit
- Option 57 – 20" Slide Kit
- Option 58 – 24" Slide Kit

The rackmount ear kit provides the basic hardware necessary to rackmount the CT-100C chassis. Because the chassis is only 15" wide, standard rack support rails cannot provide mechanical support to the chassis. If the equipment mounted below the CT-100C cannot provide mechanical support to the chassis, either 20" or 24" slides will be required to support the chassis in the rack. The rackmounting ears are designed to allow the chassis to be flush mounted in the rack or recessed 4".

The rackmount door kit provides the necessary hardware to install either a 1/8" thick aluminum door or a 1/8" thick acrylic door in front of the rackmounted chassis. These options require that the rackmount ear kit also be installed and configured for recessed mounting. The door may be customer modified to hold connectors, controls, indicators, and similar components.

The 20" and 24" slide kits provide the ability to easily remove the chassis from the rack for servicing and provides mechanical support for the chassis when installed in the rack. The 20" slide kit is used when the chassis is flush mounted in the rack. If the chassis is to be recess mounted, then the 24" slides are required.

RACKMOUNT KIT INSTALLATION

The rackmount kit (Option 59) provides the basic hardware necessary to rack mount the CT-100C chassis. With the chassis being only 15" wide, standard rack support rails cannot provide mechanical support to the chassis. If the equipment mounted below the CT-100C cannot provide mechanical support to the chassis, either 20" or 24" rack slides will be required to support the chassis when installed into the rack. The rackmounting ears are designed to allow the chassis to be flush mounted in the rack or recessed 4".

Required Tools

1. #2 Phillips Screwdriver

Parts List

QTY	ITEM	VTI P/N
4	Screw, 6-32 x 1/2", Phillips/Sems	37-0028-050
1	Bracket, Rack Flange w/ hinge mounting holes	41-0135-000
1	Bracket, Rack Flange	41-0135-001

Assembly Procedure

1. Remove the four (4) black plastic feet from the bottom of the chassis.
2. Lay the chassis on a protected work surface on its long side with the voltage monitor LEDs of the chassis facing front with the power switch toward the top.
3. Locate and remove four black plastic feet on the side of the chassis and four black plastic feet on the bottom of the chassis. Retain the feet if restoring the chassis to its original portable use is anticipated.
4. Find two threaded holes on each side of the chassis (the plastic feet were attached to two of these holes) towards the front of the unit.
5. Line up the rackmount ears with the threaded holes selecting the flush or recessed position as desired. Refer to the rackmount ear Figure 1-4 for visual assistance.
6. Secure the rack ears using the supplied #8-32 hardware.

Before installing the chassis into an EIA switch rack, the chassis handle should be removed. This can be done by doing the following:

1. Remove the four screws located near the handle.
2. Remove the two black decorative covers at each end of the carrying handle using the flat blade screwdriver. Place a piece of paper under the screwdriver blade to prevent scratching the chassis cover.
3. Remove the four Phillips screws holding the handle in place and then remove the handle itself. Retain the carrying handle components if there may be some need to restore the chassis to its original portable use in the future.

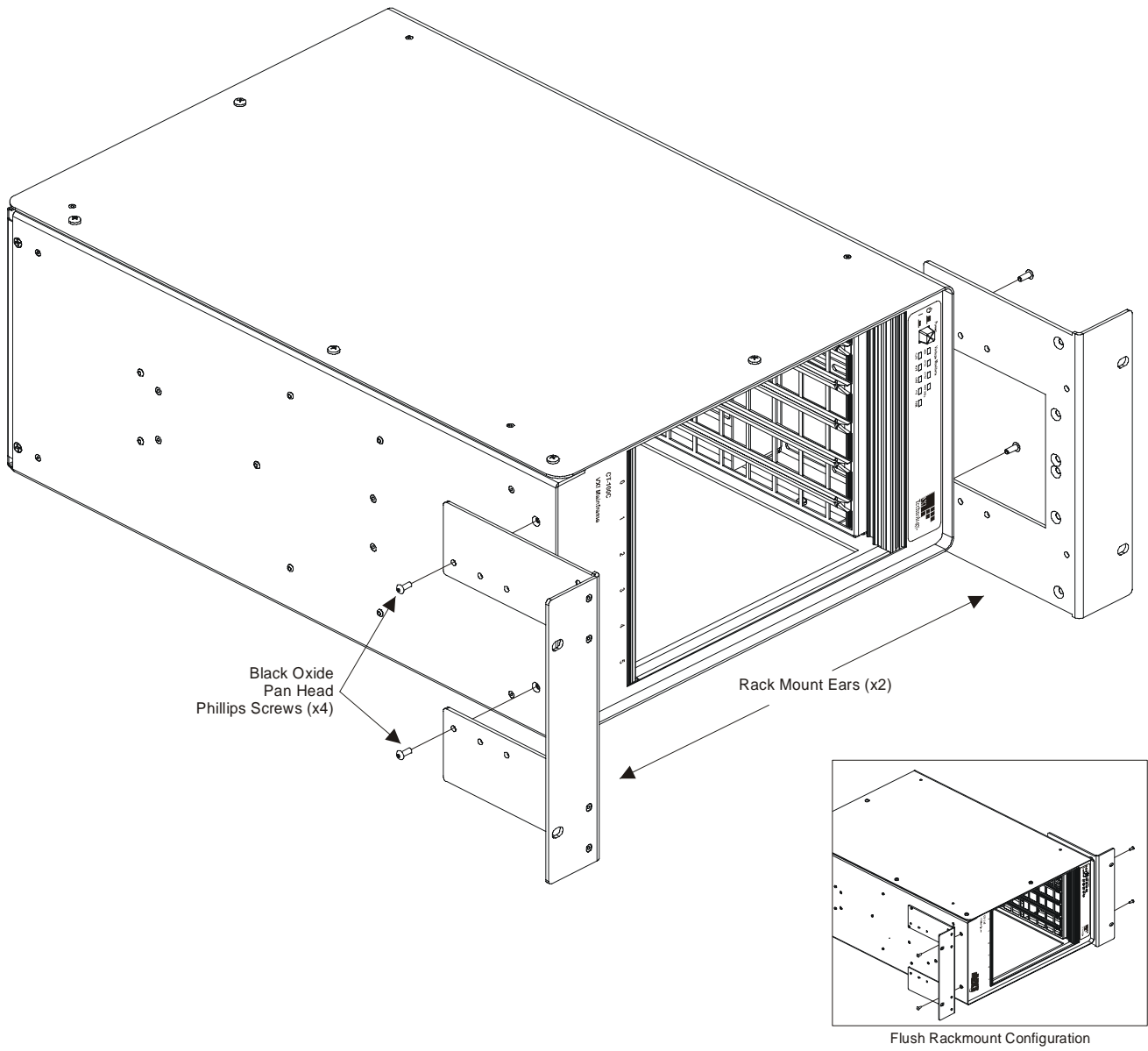

* Recessed Rackmount Installation Shown

FIGURE 1-4: RACKMOUNT EAR INSTALLATION DIAGRAM

RACK SLIDE INSTALLATION (20" AND 24")

The 20" and 24" slide hardware kits (Options 63 and 64, respectively) provide standard flanges to mount the slides into standard EIA relay racks. It should be noted that the slide flanges in the front should be installed behind the rack's front panel mounting rails. This will allow the rackmounting ears to sit flush with the front of the rack. It should also be noted that although the hardware provided in this kit will provide all the necessary components to successfully install the CT-100C into a rack, there are many variations in how EIA relay racks are designed and additional adapter hardware may be required to install the chassis. Please refer to the relay rack manufacturer's catalog for additional options.

This procedure provides instructions for installing the 20" or 24" slide kits. Note that the 20" and 24" slide kits are identical except for the length of the slide units. A 20" slide kit is used when the chassis is flush mounted and a 24" slide kit is used when the chassis is recess mounted.

Required Tools

1. #2 Phillips Screwdriver
2. 1/8" Flat Blade Screwdriver

Parts List

QTY	ITEM	VTI P/N
2	Slide, Rack Mount, Steel, 20"	37-0054-020
	- or -	
2	Slide, Rack Mount, Steel, 24"	37-0054-024
1	Hardware Kit, Rack Mount Slide, Steel	37-0055-000
6	Screw, 8-32 x 3/8" Pan Head Phillips, Sems Zinc	37-0073-037
6	Screw, 8-32 x 1/4" Pan Head Phillips, Steel/Zinc	37-0074-025
4	Screw, 8-32 x 3/8", F/H Undercut Phillips, Zinc	37-0115-037
2	Bracket, Slide, Front	41-0108-000
1	Bracket, Slide, Top Side	41-0131-000
1	Bracket, Slide, Bottom	41-0132-000

Assembly Instructions

1. Lay the chassis on a protected work surface on its long side with the voltage monitor LEDs of the chassis facing front with the power switch toward the top.
2. If the rackmount ears were installed flush, remove the rackmount ears and install the front slide bracket to them as shown in the assembly drawing using a flat head screw driver. If the rackmount ears were installed recessed, simply install the slide brackets onto the ears as shown on the following page.
3. Reinstall the rackmount ears (if necessary).
4. Install the top and bottom slide brackets using 1/4" Phillips pan head screws. Note that the slide mounting holes should be oriented below the centerline of the chassis.

5. Locate the slide hardware kit provided. Install the rack flanges to the slides as required by the application using the hardware in the kit. Note that the screws are inserted from the inside of the slides and the nuts would show on the outside.
6. Install the slides to the mounting brackets already installed on the chassis using the provided hardware.

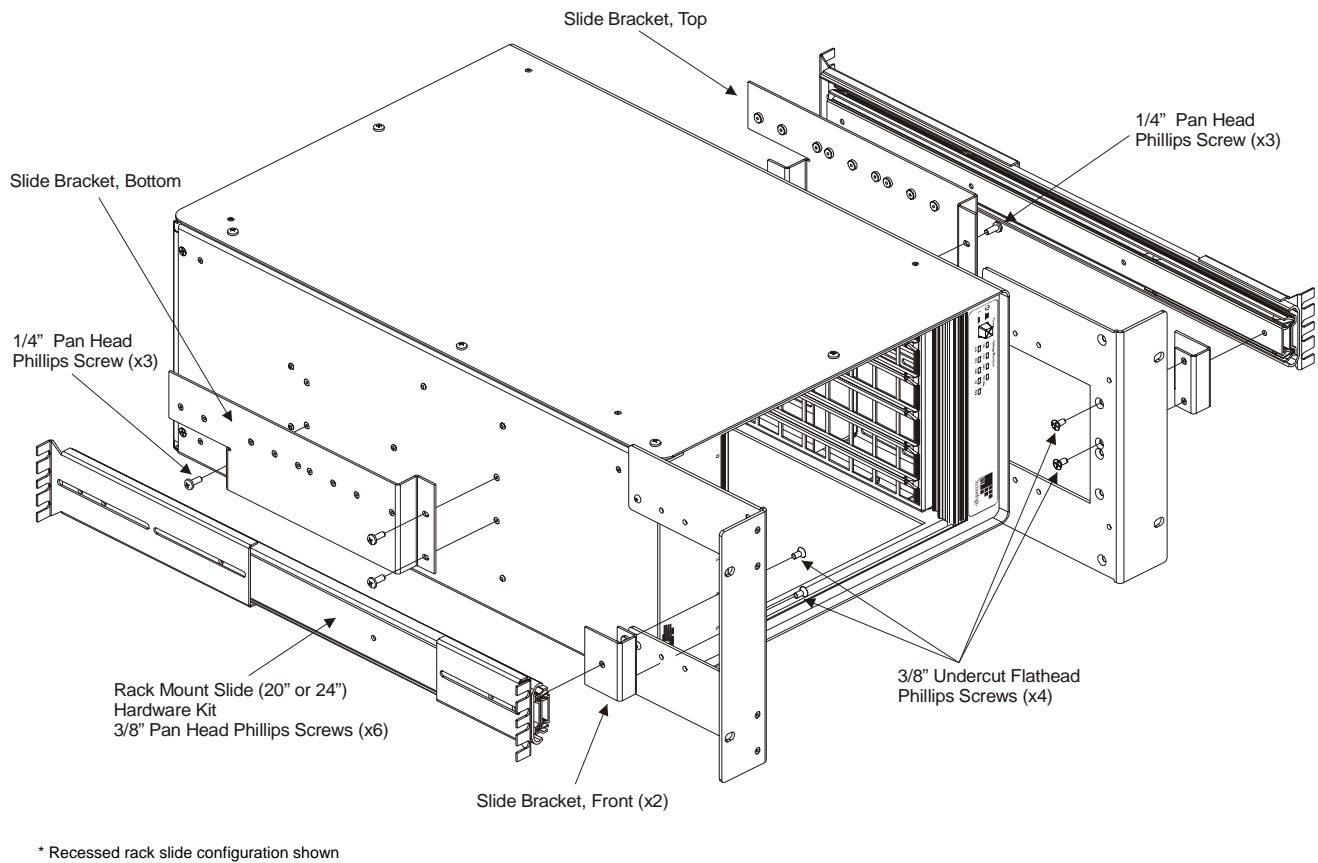

FIGURE 1-5: RACK SLIDE INSTALLATION DIAGRAM

RACKMOUNT DOOR KIT INSTALLATION

The rackmount door kit (Option 60) provides the necessary hardware to install a 1/8" thick aluminum door in front of the rackmounted chassis. This option requires that the rackmount ear kit also be installed and configured for recessed mounting. The door may be customer modified to hold connectors, controls, indicators and similar components.

Required Tools

1. #2 Phillips Screwdriver
2. 1/8" Flat Blade Screwdriver
3. 11/32" Open Ended Wrench

Parts List

QTY	ITEM	VTI P/N
2	Screw, 6-32 x 1/2" Pan Head Ph, Sq Cone Sems Zinc	37-0028-050
2	Nut, Hex, 6-32, Zinc/Steel	37-0030-632
1	Latch, Vise Action, Know Style, Black	37-0065-000
2	Hinge, Adjustable Damping, Black	37-0066-000
8	Screw, 8-32 x 3/8" Pan Head Phil, M/S, Blk Zinc	37-0079-037
4	Screw, 8-32 x 3/8" Flat Head Phillips, Zinc	37-0080-037
1	Latch, Door, Rackmount, CT-100C	41-0133-000
1	Door, Front, Rackmount, CT-100C	41-0134-000
2	Brace, Rackmount, CT-100C	41-0136-000

Assembly Procedure

1. Lay the chassis on a protected work surface on its long side with the voltage monitor LEDs of the chassis facing front with the power switch toward the top.
2. Locate two rackmount (cross) braces. Install one each along the front of the flanges (one on top and one on the bottom) using four (two ea.) #8 flathead screws. The lip along the long edge of each brace goes toward the front and pointing inside. The braces fit over the flanges and the screws are placed from the inside going through the flange and then into the brace.
3. Locate the front door and two hinges. Install the two hinges to the front door using four black screws provided.
4. Locate the latch kit and install it into the door from the side where the hinges are mounted.
5. Locate the door latch bracket and install it on the rackmount ear opposite the end where the hinges will be installed. Use Figure 1-6 as a reference.
6. Locate the four tapped holes on the front surface of the rackmount ear to which the door is to be attached.
7. Install the door by its hinges to the rackmount ear using four black screws provided with the option kit.
8. Test that the door opens and closes smoothly and adjust the latch as necessary to secure the door when latched close.

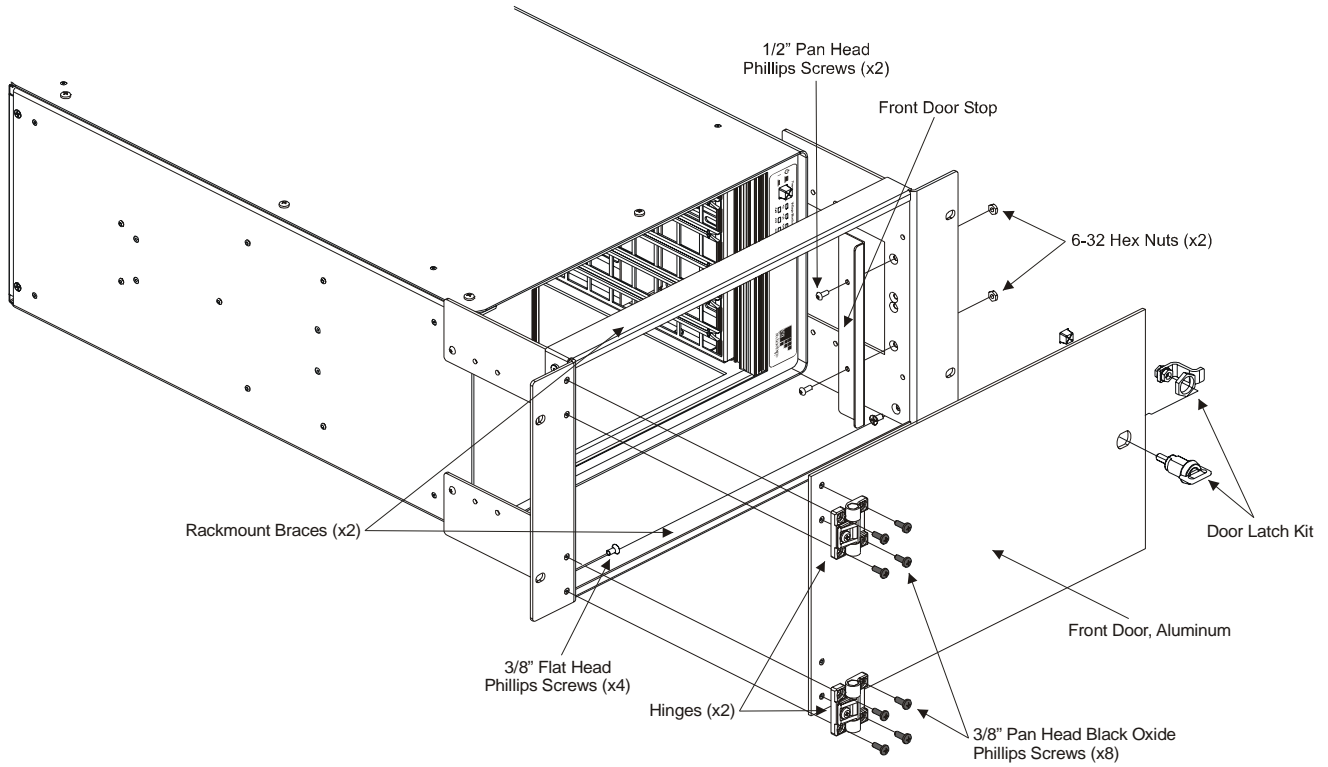

FIGURE 1-6: RACK DOOR INSTALLATION DIAGRAM

ACRYLIC RACKMOUNT DOOR KIT INSTALLATION

An acrylic rackmount door is offered as an alternative to the aluminum rackmount door. The kit (Option 65) provides the necessary hardware to install a 1/8" thick acrylic door in front of the rackmounted chassis. An installation diagram is provided on the following page for ease of assembly. This option requires that the rackmount ear kit also be installed and configured for recessed mounting.

Required Tools

1. #2 Phillips Screwdriver
2. 1/8" Flat Blade Screwdriver
3. 11/32" Open Ended Wrench

Parts List

QTY	ITEM	VTI P/N
2	Screw, 6-32 x 1/2" Pan Head Phillips, Sems Zinc	37-0028-050
2	Nut, Hex, 6-32, Zinc/Steel	37-0030-632
1	Latch, Vise Action, Knob Style, Black	37-0065-000
2	Hinge, Adjustable Damping, Black	37-0066-000
4	Screw, 8-32 x 3/8" Pan Head Phillips, Black Oxide	37-0079-037
1	Stop, Front Door, CT-100C	41-0133-000
1	Door, Front, CT-100, Acrylic	41-0303-000
2	Brace, Rackmount, CT-100C	41-0136-000
4	Nut, Hex, 8-32, Zinc/Steel	37-0030-832
4	Washer, Split Lock, 8-32 Zinc	37-0013-008
4	Washer, Flat 8-32, Zinc	37-0012-008
4	Screw, 8-32 x 1/2" Pan Head Phillips, Black Oxide	37-0079-050
4	Screw, 8-32 x 3/8" Flat Head Phillips, Zinc	37-0080-037

Assembly Procedure

1. Lay the chassis on a protected work surface on its long side with the voltage monitor LEDs of the chassis facing front with the power switch toward the top.
2. Locate two rackmount (cross) braces. Install one each along the front of the flanges (one on top and one on the bottom) using four (two ea.) #8 flathead screws. The lip along the long edge of each brace goes toward the front and pointing inside. The braces fit over the flanges and the screws are placed from the inside going through the flange and then into the brace.
3. Locate the front door and two hinges. Install the two hinges to the front door using four 1/2" black oxide pan head screws through the holes of the hinge with the flat washer in contact with the door and with the split lock washer between the hex nut and the flat washer.
4. Locate the latch kit and install it into the door from the side where the hinges are mounted.
5. Locate the door latch bracket and install it on the rackmount ear opposite the end where the hinges will be installed. Use Figure 1-7 as a reference.
6. Locate the four tapped holes on the front surface of the rackmount ear to which the door is to be attached.

7. Install the door by its hinges to the rackmount ear using four 3/8" black pan head screws provided with the option kit.
8. Test that the door opens and closes smoothly and adjust the latch as necessary to secure the door when latched close.

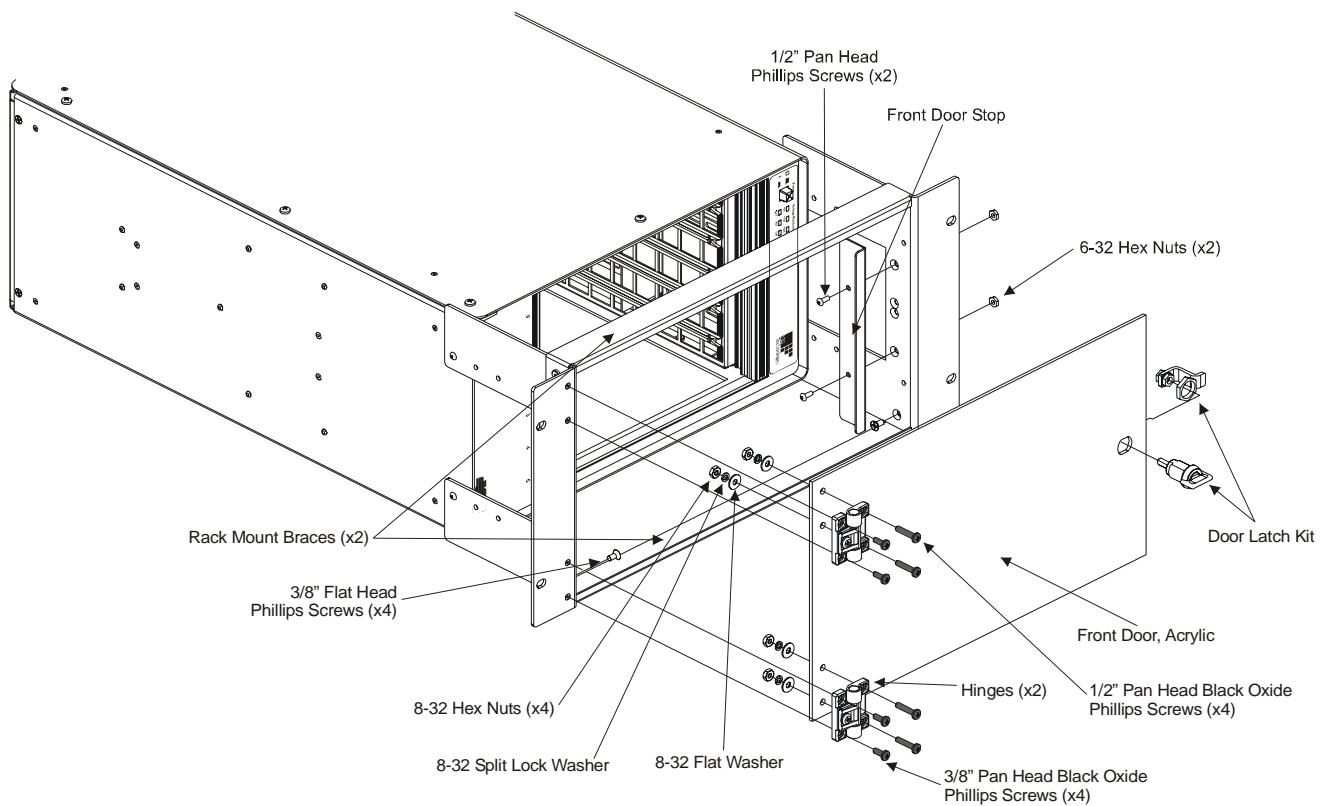

FIGURE 1-7: ACRYLIC RACK DOOR INSTALLATION DIAGRAM

INSTALLATION OF VXI MODULES

OVERVIEW

After the successful installation of rackmount accessories, the chassis is ready for installation of the VXIbus base units (i.e. an SMP1100, SMP1200, etc.). It is recommended that the instruments be installed after rackmount accessories have been installed to avoid any unnecessary physical strains that may be incurred during the installation of the accessories. Whether single- or double-wide, the process of installation is simple.

Required Tools

1. Slotted screw driver

Installation Procedure

Install C-size modules directly into the mainframe as follows:

1. To prevent damage to the module, insure the mainframe is powered off.
2. Insert the module into the mainframe by aligning it with both the upper and lower card guide of the desired slot. The card guide for the module is the right, longer guide-pair of each guide set.
3. Gently push the module into the slot until it seats into the backplane connectors. The front panel of the module should be flush with mainframe.
4. Tighten the mounting screws at the top and bottom of the module.

DISCONNECTING THE MAINFRAME

To disconnect the CT-100C from its installation, simply follow the instructions below:

1. Place the mainframe in standby by depressing the power switch.
2. Remove the power cord from the mainframe to ensure that no power is running to the mainframe.
3. Remove all cabling associated with the VXI modules installed in the CT-100C.
4. If the chassis is rack mounted, remove the chassis from the rack by removing the screws that attach the mainframe to the rack.

Rackmount options can be removed from the mainframe at this time if desired.

SECTION 3

SERVICE INFORMATION

INTRODUCTION

There are no operating instructions required for the CT-100C VXibus chassis. After the chassis is installed, operation is completely transparent to the operator. Just plug in the instruments then power up the chassis.

NOTE Service should only be performed by qualified personnel.
Le service devrait seulement être assuré par le personnel qualifié.

REPLICABLE PARTS LIST

The following table lists the parts that can be replaced on the CT-100C chassis.

Description	Part Number
Final Assembly, Power Supply Replacement Kit, CT-100C	70-0271-000

CT-100C POWER SUPPLY REPLACEMENT

The CT-100C should operate without the need for service. In the event that the cooling fans or power supply must be replaced, they are contained in a single, easy to remove module. Replacement of the power supply can be accomplished as follows:

1. Remove the AC power cord from the chassis.



To avoid the possibility of shock, wait a minimum of ten seconds for electricity to dissipate from the mainframe after removing power.

Pour éviter la possibilité de choc, attendez dix secondes au minimum afin que l'électricité se dissipe l'unité centrale.

2. Locate the six screws at the rear of the chassis attaching the power supply to the mainframe and remove all six.
3. Locate the two handles on the power supply and firmly pull the module straight back.
4. Locate the replacement power supply module and bring it up to the rear of the chassis.
5. Back the new power supply module into the rear of the chassis. Ensure that the connector on the power supply is in line with the mating connector on the power interface board.
6. Seat the power supply module firmly in place and install the previously removed screws to 9.5 lbf/in (11.0 kgf/cm).
7. Verify that the front panel power switch is in the OFF position and reattach the power cord.

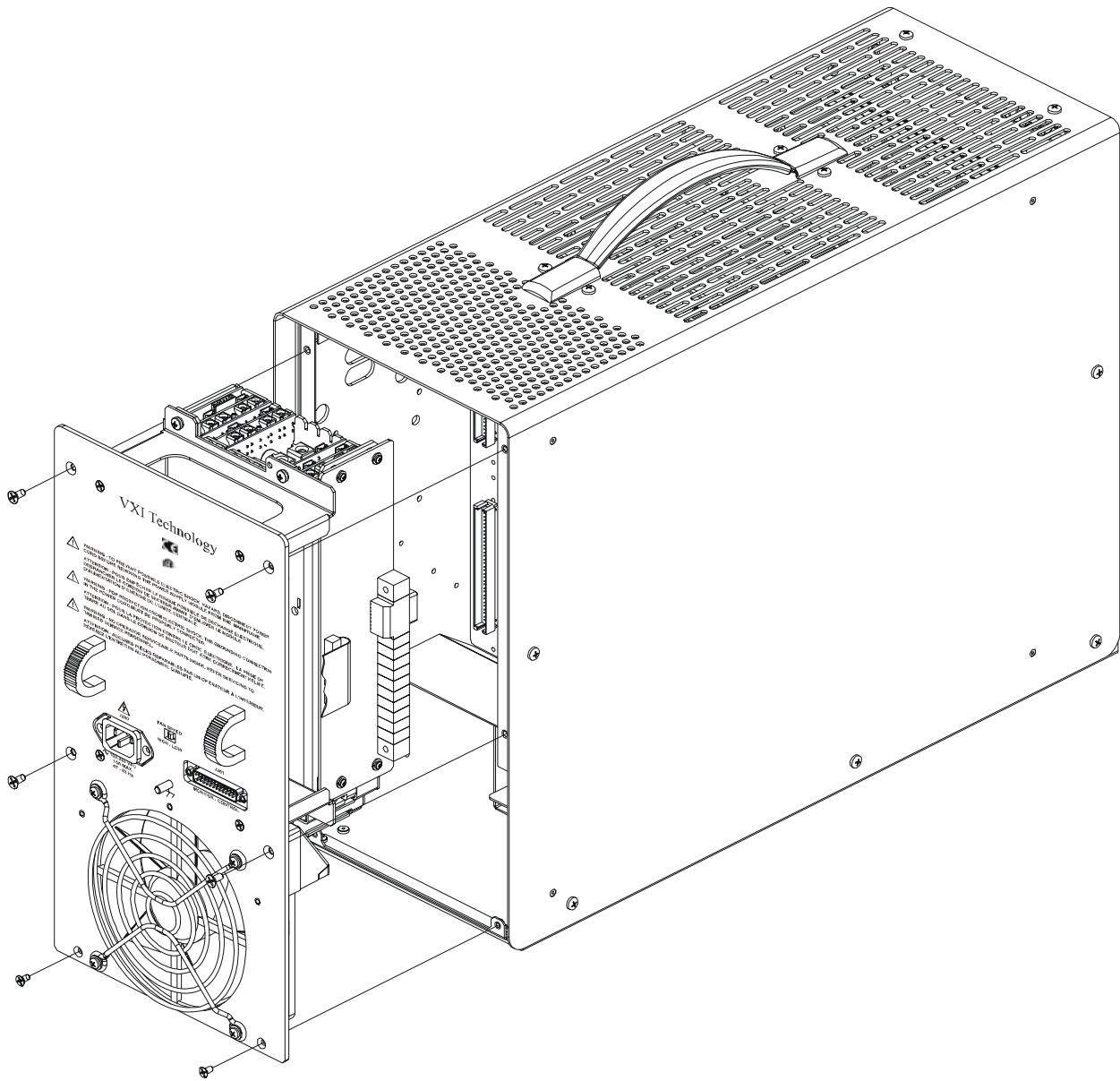

FIGURE 2-1: POWER SUPPLY REPLACEMENT DIAGRAM

CLEANING THE MAINFRAME

During normal operation, dust is likely to accumulate inside the power supply of the CT-100C. To remove this dust, power down the chassis and remove the power cord. Follow the instructions provided on the previous page to remove the power supply from the mainframe. After removing the power supply, use a pressurized air can to remove any dust present.

INDEX

Numerics

5V STANDBY	12
usage	23

A

airflow	12, 18
---------------	--------

B

backplane	12, 34
backplane configuration	12
base unit installation	34

C

card guide	34
cleaning	40

D

disconnecting the mainframe	35
dynamic current	18

F

fan speed	24
HIGH speed mode	24
LOW speed mode	24
fuse	18

J

J201 connector	22
jumpering	12

M

mainframe features	14
MTBF	17
MTTR	17

P

peak current	18
power supplies	12
power supply replacement	38

R

rack mount	25
rack mounting	12
rack slide	25
rackmount	13
remote power	22
replicable parts	37

S

specifications	17, 18
cooling	18
environmental	17
general	17
power	18

V

voltage	18
VXibus	12

W

WEEE	6
------------	---